

PowerSafe®

Sustainable solutions

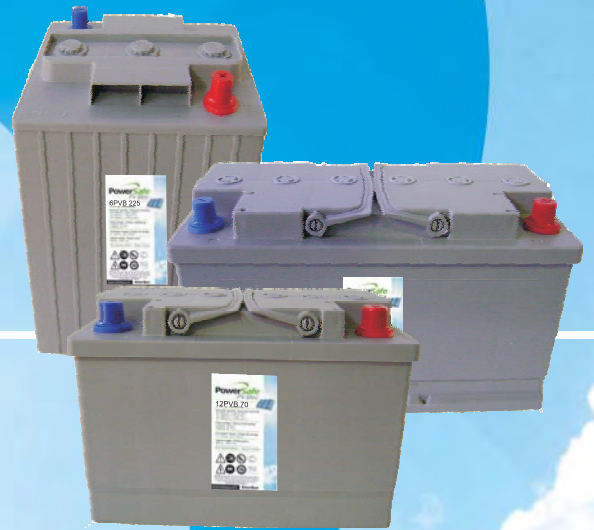

PowerSafe® PV Bloc

The PowerSafe® PV Bloc range has been specifically developed for renewable energy applications and in particular solar energy systems.

These bloc batteries are optimised for repeated deep cycling and high reliability. This balanced combination of features makes PV blocs the ideal solution for many of the most demanding applications and particularly for unmanned or remote installations where the highest level of reliability is essential.

The design brings together Valve Regulated Lead Acid (VRLA) technology and grid plates with a special alloy to produce an exceptional combination of benefits.

VRLA technology has been enhanced to withstand the repeated, deep discharge of cells and blocs used for solar energy storage. It avoids the water loss associated with conventional lead acid batteries and therefore eliminates the need for topping-up. The use of a gel electrolyte means there is no free acid inside the cell.

Key Benefits

- Capacities from 70Ah to 225Ah at the 120 hour rate (C120)
- Up to 1410 cycles to 25% depth of discharge
- Maintenance free VRLA technology eliminates periodic water refilling
- No electrolyte stratification (Gel electrolyte)
- No equalization charging required
- New plate technology improves battery design life even under deep discharge conditions
- Low self discharge
- Ensures reliable service, support and quality.

EnerSys
Power/Full Solutions

General Specifications

Type	Technology	Nominal Voltage (V)	Number of Terminals	Nominal Capacity (Ah)		Nominal Dimensions						Short Circuit Current (A)	Internal Resistance (mΩ)		
				10 hr rate to 1.80Vpc @20°C	120 hr rate to 1.85Vpc @25°C	Length		Width		Height				Typical Weight	
						mm	in	mm	in	mm	in	kg	lbs		
12 PVB 70	Flat plate Gel	12	2	57	70	277	10.9	175	6.9	189	7.4	21.0	46.3	1517	8.07
12 PVB 91	Flat plate Gel	12	2	75	91	354	13.9	175	6.9	189	7.4	25.0	55.1	1700	7.29
12 PVB 121	Flat plate Gel	12	2	109	121	344	13.5	172	6.8	276	10.9	38.0	83.7	1865	6.62
6 PVB 225	Flat plate Gel	6	2	195	225	244	9.6	190	7.5	270	10.6	31.0	68.3	2048	3.11

Notes: The electrical values shown in the table relate to performance from a fully charged condition at ambient temperature of +25°C. Height shown is overall height, including connectors and shrouds.

Installation and Operation

- Optional racking offers easy installation and space saving accommodation.

Standards

- Cycle life in accordance with IEC 60896-21/22.
- Low ventilation requirements according to EN 50272-2.
- Manufactured in EnerSys® ISO 9001 and ISO 14001 certified production facilities.

Construction

Positive electrode: flat plate with lead calcium tin grid

Negative electrode: lead calcium grid

Separators: low resistance microporous material

Container and lid: polypropylene

Electrolyte: sulphuric acid immobilised as a gel

Terminals: automotive type

Pressure relief valve: one way valve with flame arrestor

12 PVB 70

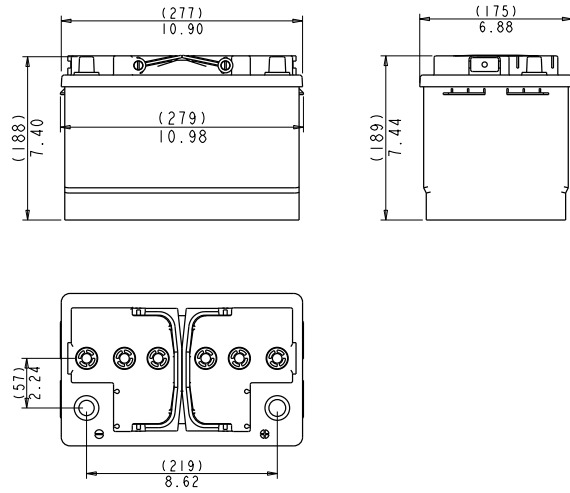

12 PVB 91

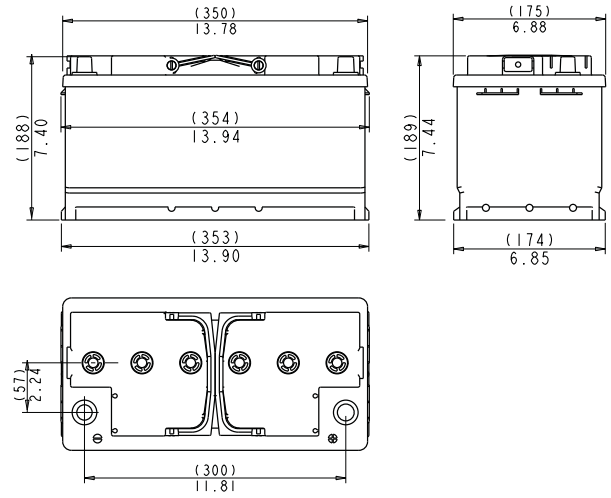

12 PVB 121

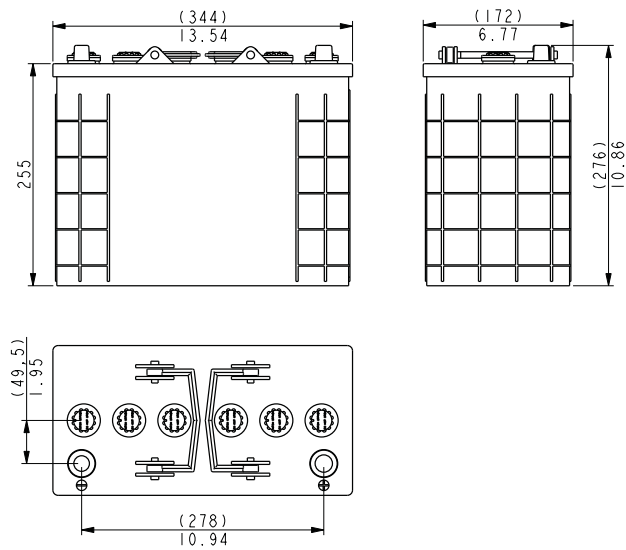

6 PVB 225

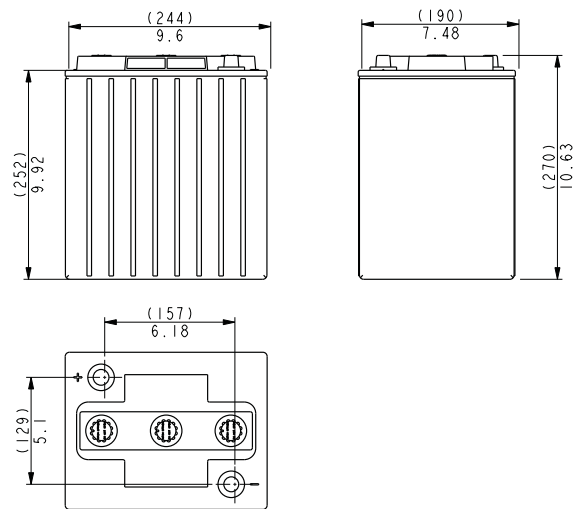

PowerSafe® PV Bloc Renewable Energy Applications
 Number of Cycles vs Depth of Discharge (25°C)

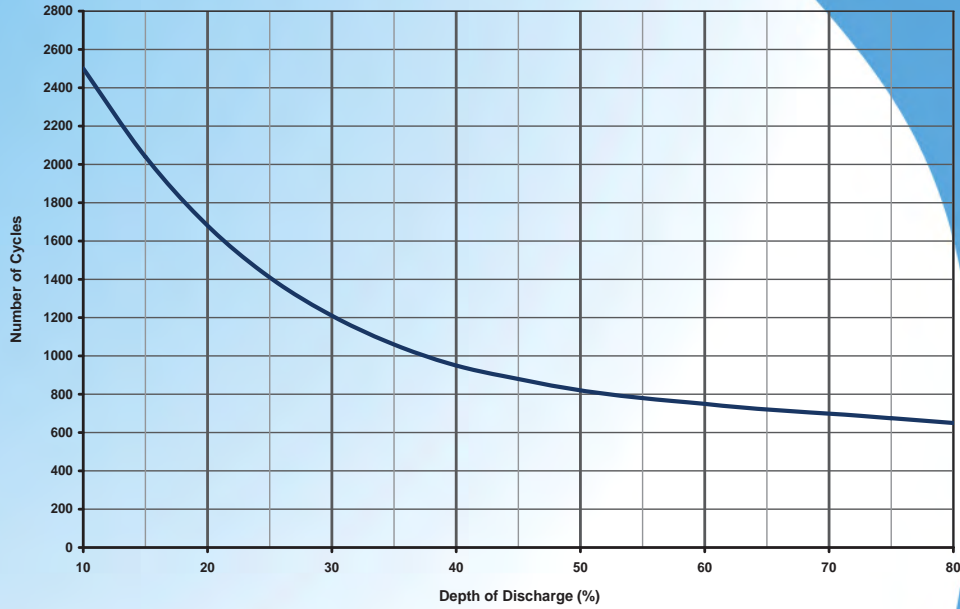

Batteries for renewable energy applications
 Derating factor for number of cycles vs average cell temperature

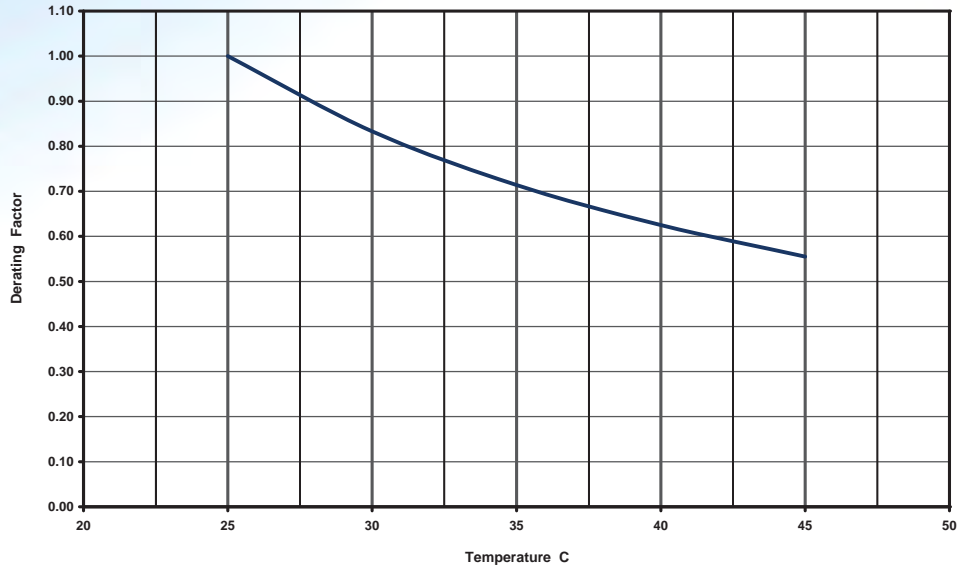

Publication No. EN-PS-PV Bloc-RS-002 - July 2011 - Subject to revisions without prior notice. E & E.O.



Global & Americas Headquarters

EnerSys
 P.O. Box 14145
 Reading
 Pennsylvania 19612-4145
 USA
 Tel. +1-610-208-1991
 Fax +1 610-372-8457

Regional Headquarters

EnerSys Europe (EMEA)
 Löwenstrasse 32
 8001 Zürich
 Switzerland
 www.enersys-emea.com

EnerSys Asia
 152 Beach Road
 Gateway East Building
 Level 11
 189721 Singapore
 Tel: +65 6508 1780
 Fax +65 6292 4380

Please refer to the website address for details of your nearest EnerSys office: www.enersys-emea.com

© 2011 EnerSys®. All rights reserved. Trademarks and logos are the property of EnerSys and its affiliates unless otherwise noted.

PowerSafe®

Sustainable solutions



PowerSafe® TS

The PowerSafe® TS range offers a high-performance, long-life solution for renewable energy applications.

PowerSafe® TS cells are based on conventional, vented technology and designed for renewable energy applications that require maximum cycle life with the highest level of reliability. They are particularly suitable for use in solar energy installations, ensuring a continuity of electrical supply during the hours of darkness or during periods of reduced sunshine.

Reduced maintenance is achieved through the use of additional electrolyte which means cells only have to be topped-up once a year. This helps to keep down maintenance costs and makes them an ideal solution for many remote or unmanned locations.

Tubular positive plates are widely used in batteries for particularly demanding applications. In the TS range they have been optimised to give an extended cycle life and increased capacity.

Key Benefits

- Capacities from 300Ah to 4580Ah at the 120 hour rate (C120)
- Products available in filled or dry charged versions
- Up to 5200 cycles to 25% depth of discharge
- Topping up required once a year only
- Minimal maintenance required
- Excellent operational safety including: fully insulated connectors and terminals, acidproof flame arrestor plug for each cell, protection of polarities during transport

EnerSys
Power/Full Solutions

General Specifications			Nominal Capacity (Ah)		Nominal Dimensions						Typical Weight Dry charged		Typical Weight Acid Filled		Electrolyte Volume		Short Circuit Current	Internal Resistance
Type	Nominal Voltage (V)	Number of Terminals	10 hr rate to 1.80Vpc @20°C	120 hr rate to 1.85Vpc @25°C	Length		Width		Height		kg	lbs	kg	lbs	Litres	US Gal	(A)	(mΩ)
					mm	in	mm	in	mm	in								
TLS 4	2	2	220	300	103	4.06	206	8.12	389	15.33	13.0	28.6	18.0	39.8	3.9	1.0	2059	1.02
TLS 5	2	2	270	367	124	4.89	206	8.12	389	15.33	15.5	34.2	21.9	48.2	4.9	1.3	2625	0.8
TLS 6	2	2	323	440	145	5.71	206	8.12	389	15.33	18.1	39.8	25.6	56.5	5.8	1.5	3000	0.7
TVS 4	2	2	340	460	124	4.89	206	8.12	505	19.9	18.4	40.6	27.3	60.3	6.9	1.8	2838	0.74
TVS 5	2	2	390	530	124	4.89	206	8.12	505	19.9	21.5	47.3	30.0	66.2	6.6	1.7	3281	0.64
TVS 6	2	2	470	640	145	5.71	206	8.12	505	19.9	25.1	55.3	35.4	78.0	7.9	2.1	3750	0.56
TVS 7	2	2	550	745	166	6.54	206	8.12	505	19.9	28.7	63.2	40.7	89.7	9.2	2.4	4200	0.5
TYS 5	2	2	590	802	145	5.71	206	8.12	684	26.95	29.8	65.8	44.6	98.3	11.3	3.0	3621	0.58
TYS 6	2	2	670	912	145	5.71	206	8.12	684	26.95	34.0	75.0	48.4	106.7	11.0	2.9	4200	0.5
TYS 7	2	2	816	1120	191	7.53	210	8.27	684	26.95	40.5	89.2	59.6	131.3	14.8	3.9	5147	0.41
TYS 8	2	2	900	1220	191	7.53	210	8.27	684	26.95	44.6	98.4	63.2	139.4	14.5	3.8	5676	0.37
TYS 9	2	2	1040	1415	233	9.18	210	8.27	684	26.95	50.2	110.8	73.9	163.0	18.3	4.8	6625	0.32
TYS 10	2	2	1120	1523	233	9.18	210	8.27	684	26.95	54.4	119.9	77.8	171.6	18.0	4.8	7000	0.3
TYS 11	2	2	1260	1714	275	10.84	210	8.27	684	26.95	60.0	132.2	88.4	194.8	21.9	5.8	8108	0.26
TYS 12	2	2	1340	1825	275	10.84	210	8.27	684	26.95	64.1	141.4	92.3	203.5	21.6	5.7	8824	0.24
TZS 11	2	4	1560	2130	275	10.84	210	8.27	829	32.66	76.5	168.6	112.3	247.6	27.5	7.3	7554	0.28
TZS 12	2	4	1710	2335	275	10.84	210	8.27	829	32.66	81.7	180.0	117.0	257.9	27.1	7.2	8400	0.25
TZS 13	2	6	1940	2640	399	15.72	214	8.43	813	32.03	94.9	209.2	146.6	323.2	39.7	10.5	8936	0.24
TZS 14	2	6	2040	2775	399	15.72	214	8.43	813	32.03	101.8	224.5	153.4	338.2	39.6	10.5	9589	0.22
TZS 15	2	6	2150	2925	399	15.72	214	8.43	813	32.03	105.4	232.4	156.0	343.9	38.9	10.3	10294	0.2
TZS 16	2	6	2240	3050	399	15.72	214	8.43	813	32.03	110.3	243.2	160.9	354.7	38.9	10.3	11053	0.19
TZS 17	2	8	2430	3310	487	19.19	212	8.35	813	32.03	122.0	269.0	182.2	401.6	48.5	12.8	11667	0.18
TZS 18	2	8	2555	3480	487	19.19	212	8.35	813	32.03	127.6	281.3	186.7	411.7	47.8	12.6	12353	0.17
TZS 20	2	8	2800	3810	487	19.19	212	8.35	813	32.03	137.8	303.8	199.8	440.5	47.6	12.6	14000	0.15
TZS 22	2	8	3090	4210	576	22.69	212	8.35	813	32.03	151.9	335.0	223.5	492.7	57.7	15.2	11053	0.14
TZS 24	2	8	3360	4580	576	22.69	212	8.35	813	32.03	162.6	358.4	235.8	519.9	56.3	14.9	16154	0.13

Notes: The electrical values shown in the table relate to performance from a fully charged condition at ambient temperature of +25°C. Height shown is overall height, including connectors and shrouds.

Installation and Operation

- Recommended temperature range: 10°C/+50°F to +40°C/+86°F (preferred value 25°C/68°F)
- Can be installed on steel or wooden racks.

Standards

- Compliant with international standard IEC 60896-11
- Compliant with international standard IEC 61427:2005.
- Manufactured in EnerSys® ISO 9001 certified production facilities.

Construction

Positive electrode: die cast tubular plate with optimum lead antimony.

Negative electrode: pasted flat plate with lead antimony alloy grid.

Separators: low resistance microporous material.

Container: moulded from durable, transparent styrene acrylonitrile (SAN) to allow electrolyte level and cell condition to be monitored visually.

Lid: made from Acrylonitrile Butadiene Styrene (ABS).

Vent plugs: safety plugs equipped with flame arrestors. Special vent plugs allowing topping-up and S.G. reading without the need to remove them, are available on request.

Electrolyte: diluted sulphuric acid with a specific gravity of 1.240 ± 0.010 (maximum level) at 25°C for a fully charged cell. Large reserve of electrolyte reduces topping-up to once a year.

Terminals: lead alloy leakproof pole with brass insert designed to give minimum resistance and maximum current flow.

Connectors: fully insulated, solid copper inter-cell connectors allow voltage measurements.

TLS, TVS, TYS 5 - TYS 6

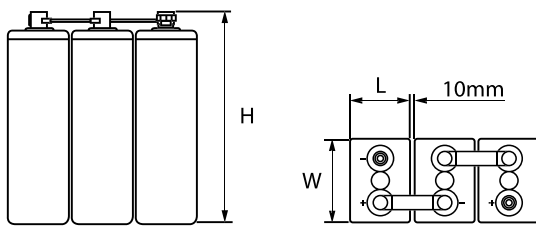

TZS 11, TZS 12

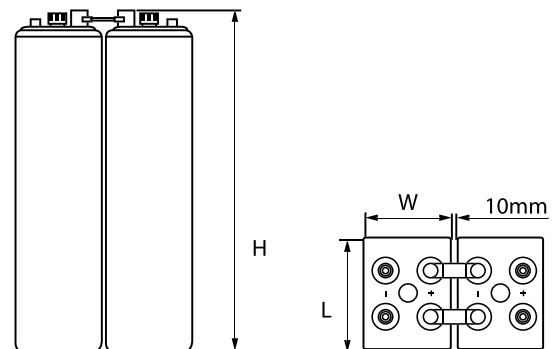

TYS 7 - TYS 12

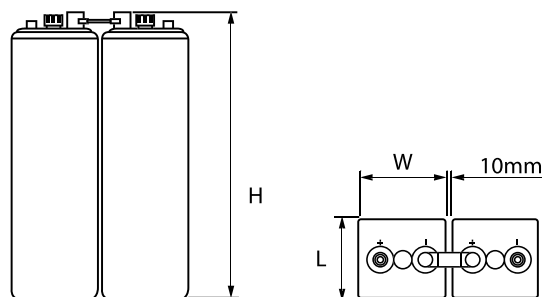

TZS 17 - TZS 24

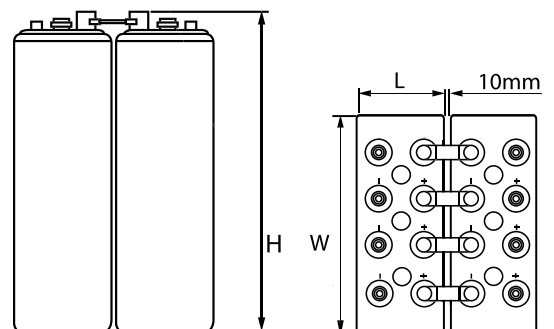

TZS 13 - TZS 16

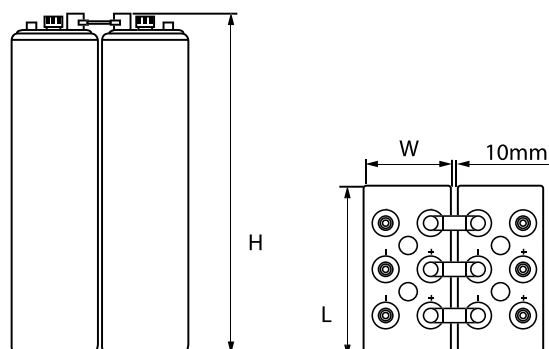

PowerSafe® TS Renewable Energy Applications
Number of Cycles vs Depth of Discharge (25°C)

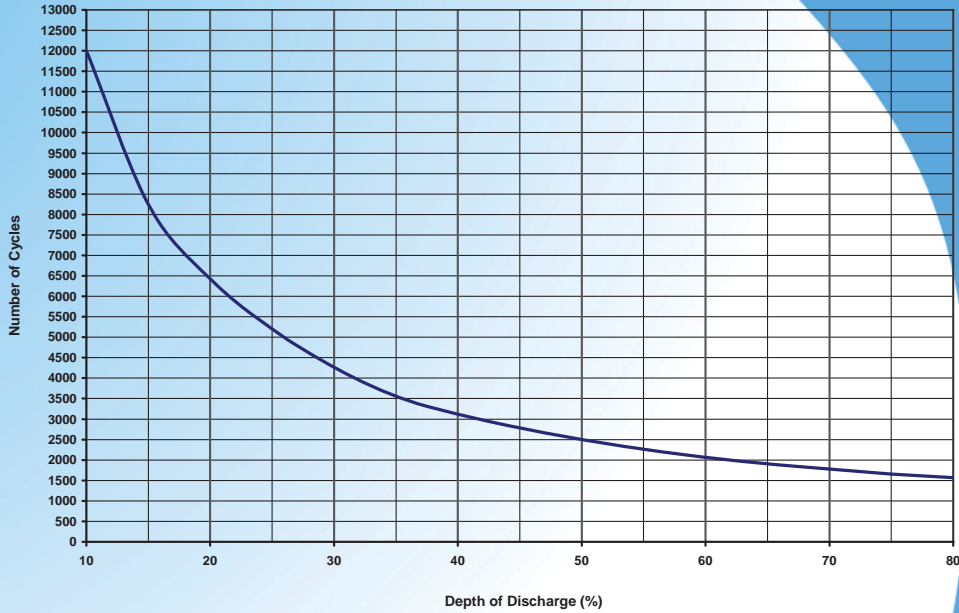

Batteries for renewable energy applications
Derating factor for number of cycles vs average cell temperature

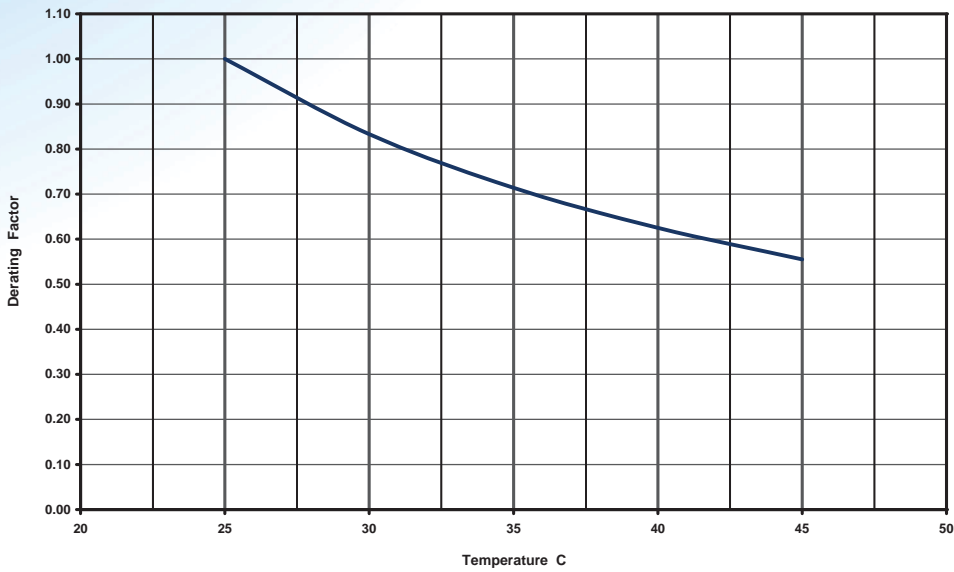

Publication No. EN-PS-TS-PG-003 - July 2011 - Subject to revisions without prior notice. E. & O.E.



Global & Americas Headquarters

EnerSys
 P.O. Box 14145
 Reading
 Pennsylvania 19612-4145
 USA
 Tel. +1-610-208-1991
 Fax +1 610-372-8457

Regional Headquarters

EnerSys Europe (EMEA)
 Löwenstrasse 32
 8001 Zürich
 Switzerland
 www.enersys-emea.com

EnerSys Asia
 152 Beach Road
 Gateway East Building
 Level 11
 189721 Singapore
 Tel: +65 6508 1780
 Fax +65 6292 4380

Please refer to the website address for details of your nearest EnerSys office: www.enersys-emea.com

PowerSafe®

Sustainable solutions



PowerSafe® OPzV

The PowerSafe® OPzV range has been specifically developed for renewable energy applications and in particular solar energy systems.

These single 2 volt cells are optimised for repeated deep cycling, high reliability and very low maintenance. This balanced combination of features makes OPzV cells the ideal solution for many of the most demanding applications and particularly for unmanned or remote installations where the highest level of reliability is essential.

The design brings together Valve Regulated Lead Acid (VRLA) technology and high performance tubular positive plates to produce an exceptional combination of benefits in a single cell.

VRLA technology has been enhanced to withstand the repeated, deep discharge of cells used for solar energy storage. It avoids the water loss associated with conventional lead acid batteries and therefore eliminates the need for topping-up. The use of a gel electrolyte means there is no free acid inside the cell so it can operate horizontally and vertically and be transported safely without fear of spills.

Tubular positive plates are widely used in batteries for heavy-duty cycling applications. This robust construction has been incorporated within the OPzV design to compliment the low-maintenance features of the VRLA technology.

Key Benefits

- Capacities from 273Ah to 3932Ah at the 120 hour rate (C120)
- Up to 4400 cycles to 25% depth of discharge
- Highest EUROBAT classification - 'Long Life'
- Vertical or horizontal installation
- No topping up required
- Minimal maintenance required
- Excellent operational safety including: fully insulated connectors, immobilised electrolyte, one way pressure relief valve with integral flame arrestor

EnerSys®
Power/Full Solutions

General Specifications			Nominal Capacity (Ah)		Nominal Dimensions						Typical Weight		Short Circuit Current (A)	Internal Resistance (mΩ)
	Nominal Voltage (V)	Number of Terminals	10 hr rate to 1.80Vpc @20°C	120 hr rate to 1.85Vpc @25°C	Length		Width		Height		kg	lbs		
			mm	in	mm	in	mm	in	mm	in				
4 OPzV 200	2	2	215	273	103	4.06	206	8.12	403	15.88	19.5	43	2195	0.95
5 OPzV 250	2	2	265	343	124	4.89	206	8.12	403	15.88	23.5	51.9	2737	0.76
6 OPzV 300	2	2	320	413	145	5.71	206	8.12	403	15.88	28.0	61.8	3175	0.66
5 OPzV 350	2	2	385	484	124	4.89	206	8.12	520	20.49	31.0	68.4	3410	0.61
6 OPzV 420	2	2	465	574	145	5.71	206	8.12	520	20.49	36.5	80.5	4043	0.51
7 OPzV 490	2	2	540	678	166	6.54	206	8.12	520	20.49	42.0	92.6	4607	0.45
6 OPzV 600	2	2	705	895	145	5.71	206	8.12	695	27.38	50.0	110.3	3796	0.55
8 OPzV 800	2	4	940	1187	210	8.27	191	7.53	695	27.38	68.0	150	5200	0.40
10 OPzV 1000	2	4	1170	1491	210	8.27	233	9.18	695	27.38	82.0	180.8	6460	0.32
12 OPzV 1200	2	4	1410	1796	210	8.27	275	10.84	695	27.38	97.0	213.9	7675	0.27
12 OPzV 1500	2	4	1580	1967	210	8.27	275	10.84	845	33.29	120.0	264.6	7510	0.28
16 OPzV 2000	2	6	2110	2629	212	8.35	397	15.64	820	32.31	165.0	363.8	10048	0.21
20 OPzV 2500	2	8	2640	3272	212	8.35	487	19.19	820	32.31	200.0	441	12606	0.17
24 OPzV 3000	2	8	3170	3932	212	8.35	576	22.69	820	32.31	240.0	529.2	14964	0.14

Notes: The electrical values shown in the table relate to performance from a fully charged condition at ambient temperature of +25°C. Height shown is overall height, including connectors and shrouds.

Installation and Operation

- Cells can be installed horizontally or vertically to minimise use of floor space.
- Optional racking offers easy installation and space saving accommodation.

Standards

- Compliant with international standard IEC 60896-21/22
- Compliant with international standard IEC 61427:2005.
- Low ventilation requirements according to EN 50272-2.
- Manufactured in EnerSys® ISO 9001 and ISO 14001 certified production facilities.

Construction

Positive electrode: tubular plate with lead-tin-calcium alloy.

Negative electrode: flat plate with lead calcium alloy grid.

Separators: low resistance microporous material.

Container and lid: made from Acrylonitrile Butadiene Styrene (ABS) with optional flame retardant ABS available (UL94 V-0).

Electrolyte: sulphuric acid immobilised as a gel.

Terminals: with brass inserts and M10 stainless steel bolts. Coloured washers provided for easy polarity recognition.

Connectors:

- for vertical installation: insulated solid copper connector (30mm x 3mm).
- for horizontal installation: insulated flexible cable connectors (70mm²).

Each connector design is of the bolt-on type and allows for voltage measurements.

Pressure relief valve: one way valve with flame arrestor.

4 OPzV 200 - 6 OPzV 600

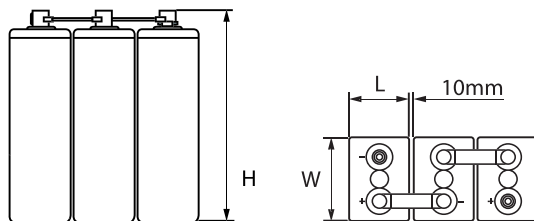

8 OPzV 800 - 12 OPzV 1500

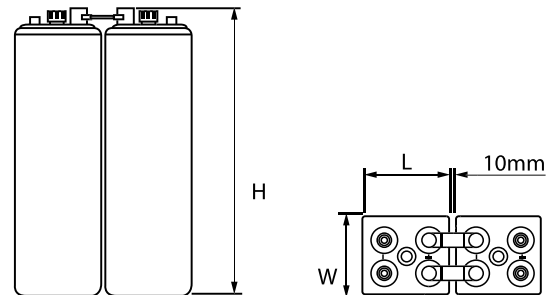

16 OPzV 2000

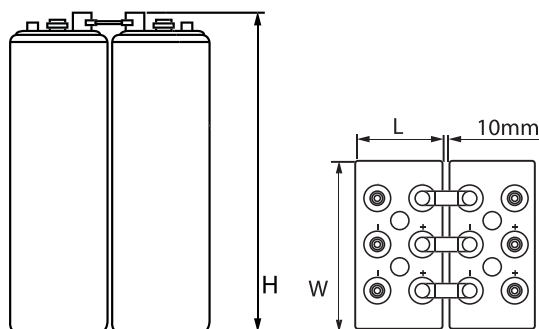

20 OPzV 2500 - 24 OPzV 3000

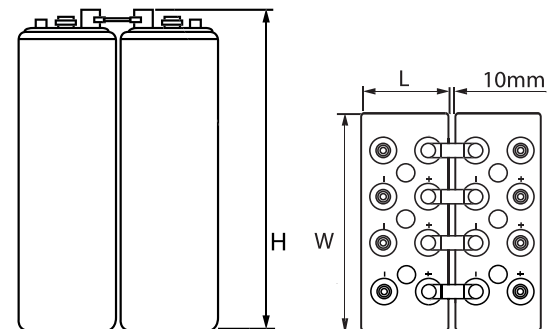

PowerSafe® OPzV Renewable Energy Applications
Number of Cycles vs Depth of Discharge (25°C)

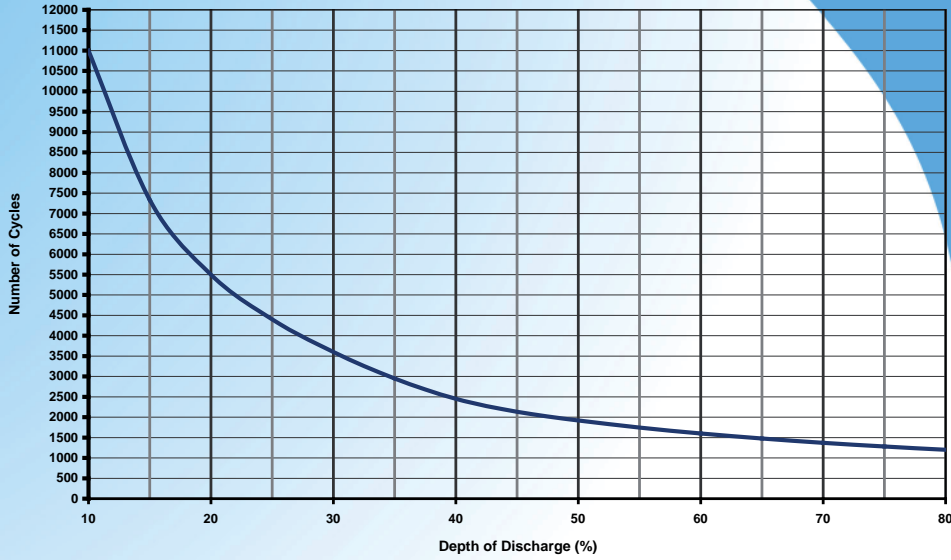

Batteries for renewable energy applications
Derating factor for number of cycles vs average cell temperature

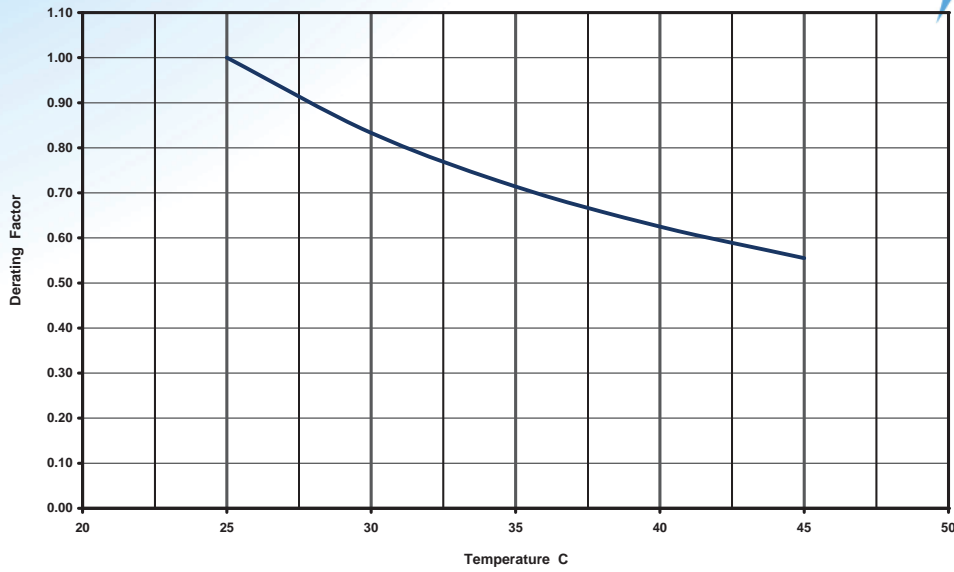

Global & Americas Headquarters

EnerSys
P.O. Box 14145
Reading
Pennsylvania 19612-4145
USA
Tel. +1-610-208-1991
Fax +1 610-372-8457

Regional Headquarters

EnerSys Europe (EMEA)
Löwenstrasse 32
8001 Zürich
Switzerland
www.enersys-emea.com

EnerSys Asia
152 Beach Road
Gateway East Building
Level 11
189721 Singapore
Tel: +65 6508 1780
Fax +65 6292 4380